

# Sparks

a one page zine of reviews, poems, stories, shorts, rants, scraps, & junk...glints of real, flickers of true, cultural triggers, mental activation, emotional light, trips, wonderment...

## Step Up to the Trough

"Get up there, now!" the man shouted. The man in the loose trousers. I was afraid to look at his zit-covered face. He had nice shoes -- black, steel-toe engineer boots.

Ahead was the trough -- as long as the building it stood against. The stench was unbearable.

"Put your face in it."

Because he meant it, because I was powerless to resist him, I bent closer to the shimmering surface of the trench. The putrid smell of semen, onions, garlic, week old garbage, mutilated decaying squirrel carcasses, spoiled fruit, rotten eggs, noxious plastic, and fire damaged

ees knifing through the water like schools of fish.

The man lifted my head out of the trough. I caught my breath. "Now, next time, open your eyes and breathe in."

"But I'll drown!"

"No you won't. You just think you'll drown. Don't be an elitist. Get in there."

I breathed in like he said. The water filled my lungs. It burned worse than it had burned my eyes -- like acid corroding my body cavity from the inside out. I struggled to get above water. He held me down. I opened my eyes -- the images were still there, swimming by, even more colorful and intense than before.

Then he lifted me by the belt and dumped my whole body into the trough. I could feel my skin shrivelling. I shrank. A shark swam by and bit off my feet. Nothing hurt any more. I grew fins and a fish tail. My eyes wouldn't close. I started opening and closing my mouth. Where my ribs used to be, I could feel the gills throbbing.

I swam along the length of the trough, back and forth.

It seemed like I was a fish for day, but my sense of smell was gone.

Suddenly, I felt a fist grab me and pull me out of the water. Another hand came at me with a knife and cleaned out all my guts. I was thrown onto a barbecue grill and cooked to perfection. Then I was eaten morsel by morsel. Spearred by fork tongs, lifted, gnawed and gnashed by yellow teeth. In the stomach and digestive track, I entered the bloodstream of the person who'd devoured me.

I never lost consciousness, even when being reduced to so many millions of cells. In fact, as I coursed through the person's body, I felt myself becoming more conscious, more aware of my disintegrating self. My cells travelled through the person's brain when he was asleep. I relaxed there. It had been a long and tiring day.

When I awoke, I opened my eyes. I looked at my pink hands and found I could squeeze them open and closed. I could smile again, could feel the pimples on my face. I put on my loose trousers and steel toe engineer boots and went to work at the trough.

- Jim Esch

## REVIEWS

### Cockeyed Ghost

#### The Scapegoat Factory

<http://members.aol.com/CGspace/>  
Big Deal  
eparachute@aol.com  
212-387-8900

Find somewhere to buy this album now! If you have a hankerin' at all for incandescent Indie Pop, Scapegoat Factory, the third album from Cockeyed Ghost, is essential listening.

Having survived a two-thirds breakup of his band, songwriter/lead vocalist Adam Marsland has endured the emotional hammering, social breakups, and disillusionment of early adulthood, only to return wiser with a new lineup and a set of stunning pop songcraft.

Cockeyed indeed. Marsland's songwriting instincts are impeccable. He covers anthemic pop rock, eighties dance-spook grooves, grunge choruses, twangin' literate folk pop, spikey punk, 70's style pop, Surf Rock, and on and on. The songs are damn good. Emotionally pure, sometimes angry, sometimes self-effacing lyrics married with intelligent song structures that are at once familiar and fresh. Thank God someone still knows how to throw a modulation into a song and make it effective! A well-placed modulation or bridge can shift a song into overdrive. Marsland has the keys. Have I said you should run out and buy this album? I have? OK.

The significant influences are plenty -- Beach Boys, Beatles, Elvis Costello, Cheap Trick, Neil Finn, Jimmy Webb, Pete Townshend, even Elton John. Marsland is one of the more versatile indie practitioners I've ever laid ears to. His voice itself is a jack-of-all trades. Sounding pretty damn close to Brian Wilson at one moment, thrashing with utter angstpunk abandon the next, all the while complementing his lead vocals with "just the right" backing vocals

### Yes Virginia

[wiseguyrecords@yahoo.com](mailto:wiseguyrecords@yahoo.com)  
<http://rocking.to/yesvirginia>  
302-633-0120

What do you get when you combine Christmas music with Progressive Rock? You get this 4 song CD. It evokes primarily 80's era Genesis, New Age Instrumental Pop, and Mannheim Steamroller -- plump on keyboard (Paul Janocha) and extended lead guitar work (Joe Merkel). Too bad the drum tracks are lame; I kept yearning for some kick ass live drum fills to beef up the yuletide vibe. Merkel's lead guitar is polished, proving the point that disparate styles can be made to dissolve into a common solution.

The gimmick, in case you haven't caught on, is setting classic Christmas songs in instrumental prog rock garb. As a novelty item, Yes Virginia succeeds. But as anything more substantial, it falls flat. Get it for your friends who can't get enough of Mike Rutherford's lead guitar style, or the ostinato bombast of a Tony Banks instrumental interlude. And your New Age crystal-sniffing comrades might be singing praises too.



-- he has a knack for fulfilling the needs of a song.

Sometimes the production quality sags under the weight of Marsland's harmonic talent. You kind of wish the production was "clearer"; because the song arrangements are so well conceived. But really, it's not awful production -- in fact as Indie productions go, it's par for the course, or a little better, and the shortcomings fail to mar the many moments of pure pop bliss, like the way Adam sings Goodbye to amicability in "Where's My Best Friend" -- it's a heart stopper. Then the witty, ironic twist at the end of "Better Off Dead". The stuff sparkles with brilliance. I could not take this CD off my player for two weeks. One of the best albums I've heard this year, in any category. Don't miss the hidden tracks either -- they're essential to wrapping up the theme of the album, which I take to be a catharsis of picking up after the bad dreams blow up in your face and finding the peace.

There's no reason why Cockeyed Ghost shouldn't rip up any number of charts, if that's what they want. According to press reports, the band smoked at the South by Southwest convention in Austin. No wonder. When you hear something this good, it stands tall and beats your brain senseless. I've said enough. Discover for yourself.

### Big Open Road

#### Without You

bahainyc@interport.net

A two song demo: Without You & Misunderstood. It's middle-of-the-road, radio-ready pop rock that recalls the Police in the days before they got too artsy. You must put yourself into the iso-chamber and become the 80's. Think haircuts -- short in front, long in back. I have to admit I was flashing on Martha Quinn a bit -- not sure if that's a good or bad thing.

Competent? Yes. Catchy? Rather. Sounds like the Police? Bingo! There's a 90's edge here that brings the sound up to date; if you like a fresh, uptempo blend to your rock, give 'em a listen..

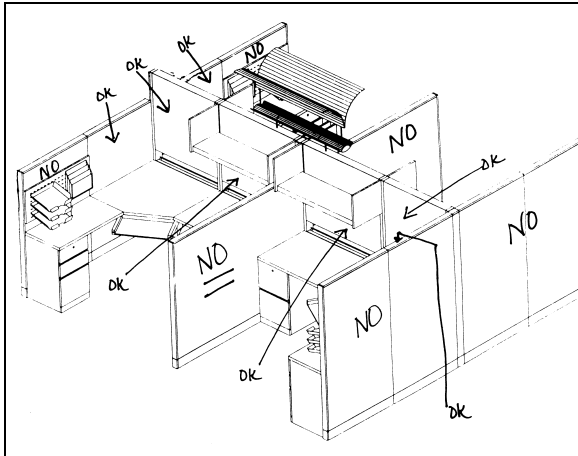

drapes and furniture filled my nostrils, my sinus cavity, and reached into my throat. I gagged and vomited for ten minutes into the trough.

After I was done, he prodded me with his steel toe. "Now put your face in it."

I still had the dry heaves, but there was no resisting.

The surface of the trough was a dance of dizzy technocolored swirls. I said a silent prayer and immersed my face in it. I could feel the man pushing the back of my head farther down. Then he lifted me up and shouted "Next time, open your eyes when you're under water."

He shoved my head back into the trough and squeezed until I opened my eyes. The water burned like ammonia and my eyes were nearly blinded by the brightness of the light. I felt faint.

The images began to come into focus -- there was the NBC peacock, the CBS eye, the MTV astronaut. There were the spinning news logos, and Cronkite, and Brinkley, and Jennings, and Rather, and Chung, and Chancellor, and Brokaw, and Shaw, and Bobbie Batista, and Brian Williams, and all the local newscasters. There were actors and actresses, celebrities and talk show hosts, employers and employ-